

产品描述:

TRM156A2S3 是一款 600V/15A 三相全桥智能功率模块，内置了低损耗沟槽栅场截止型 IGBT 和 FRD,内部集成了自举二极管 BSD，简化了客户的 PCB 设计。内部集成温度输出 VOT 功能用于检测模块内部的温度。集成多种保护功能，包含 UVLO 欠压保护，CIN 过流保护，过温保护。并兼容 3.3V, 5V 和 15V 逻辑电平。

Description

TRM156A2S3 is a 600V/15A three-phase full bridge intelligent power module with built-in low power loss trench gate field-stop IGBT and FRD, The bootstrap diode BSD is integrated inside, which simplifies PCB design. The internal integrated temperature output VOT function is used to detect the temperature inside the module. The module integrates multiple protection functions, including UVLO under voltage protection and CIN over current protection. The compatible with 3.3V, 5V, and 15V logic input.

主要特点:

- 600V/15A 三相全桥智能功率模块
- 内置低损耗沟道栅-场截止型 IGBT
- 下桥臂 IGBT 发射极输出
- 内置带限流电阻的自举二极管 BSD
- V_{OT} 线性温度输出
- 兼容 3.3V, 5V 和 15V 逻辑电平
- UVLO 欠压保护，过流保护，过温保护
- 符合 RoHS 2.0

应用:

- 变频空调压缩机驱动
- 工业伺服变频器
- 小功率变频风机水泵
- 电机驱动器

MAIN FUNCTION AND RATING

- 600V/15A three-phase full bridge intelligent power module
- Built-in Lower power loss trench gate field-stop IGBT
- N-side IGBT open emitter
- Built-in bootstrap diode with current limiting resistor
- V_{OT} linear temperature output
- Compatible with 3.3V, 5V, and 15V logic input
- UVLO under voltage protection, short circuit protection, over temperature protection
- Compliant with RoHS 2.0

APPLICATION

- Inverter air-conditioning compressor drive
- Industrial servo converter
- Low power inverter's fan and water pump
- Motor driver

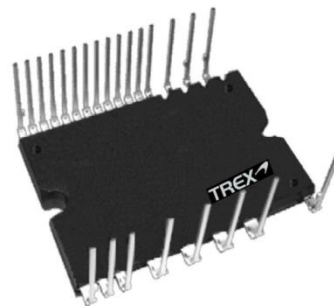

封装/Package: DIP24

订货信息 PART ORDING TABLE

订货信息 Booking information	产品名称 Product name	封装形式 Package	无卤素 Halogen Free	包装方式 Packing
TRM156A2S3	TRM156A2S3	DIP24	是 Yes	条管 Tube

内部等效电路/管脚说明

Internal Equivalent Circuit/Pin Configuration



图 1：内部等效电路
Fig1: Internal Equivalent Circuit



图 2：引脚定义图
Fig2: Pin Configuration

管脚定义/Pin Descriptions

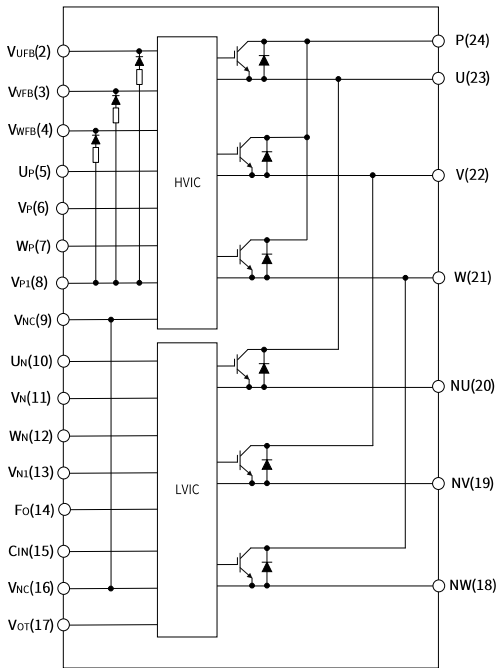
管脚编号 Pin Number	管脚名称 Pin Name	管脚描述 Pin Description
1	NC	无连接 No connection
2	V _{UFB}	U 相上臂驱动电源端子 U-phase upper arm drive power supply
3	V _{VFB}	V 相上臂驱动电源端子 V-phase upper arm drive power supply
4	V _{WFB}	W 相上臂驱动电源端子 W-phase upper arm drive power supply
5	U _P	U 相上臂控制信号输入端子 U-phase upper arm control signal input
6	V _P	V 相上臂控制信号输入端子 V-phase upper arm control signal input
7	W _P	W 相上臂控制信号输入端子 W-phase upper arm control signal input

8	V _{P1}	控制电源端子 Drive power supply
9	V _{NC}	控制电源 GND 端子 Control power supply ground
10	U _N	U 相下臂控制信号输入端子 U-phase lower arm control signal input
11	V _N	V 相下臂控制信号输入端子 V-phase lower arm control signal input
12	W _N	W 相下臂控制信号输入端子 W-phase lower arm control signal input
13	V _{N1}	控制电源端子 Drive power supply
14	F _O	故障输出端子 Fault output
15	CIN	短路保护触发电压检测端子 Short current protection input
16	V _{NC}	控制电源 GND 端子 Control power supply ground
17	V _{OT}	温度检测输出端子 Temperature detection output
18	NW	W 相下臂 IGBT 发射极端子 W-phase lower arm IGBT emitter output
19	NV	V 相下臂 IGBT 发射极端子 V-phase lower arm IGBT emitter output
20	NU	U 相下臂 IGBT 发射极端子 U-phase lower arm IGBT emitter output
21	W	W 相输出端子 W-phase output
22	V	V 相输出端子 V-phase output
23	U	U 相输出端子 U-phase output
24	P	逆变器直流输入端子 Inverter DC input
25	NC	无连接 No connection

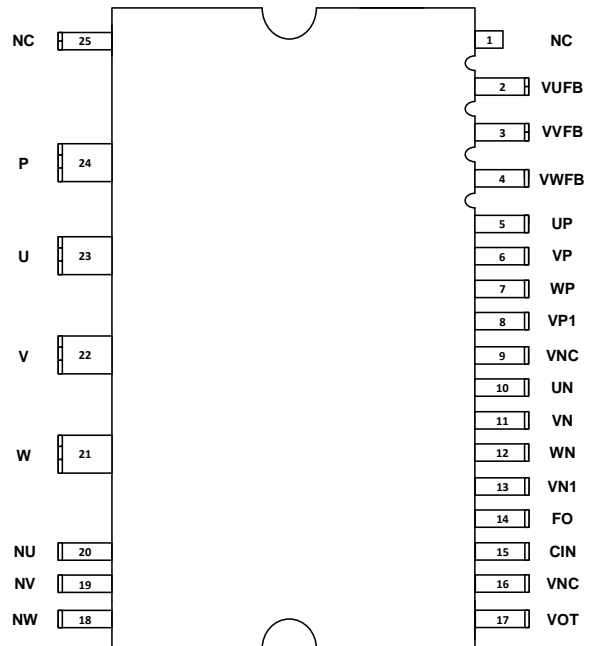
最大额定值 (T_j= 25°C, 除非特殊说明)

Absolute Maximum Ratings (T_j= 25°C, unless otherwise noted)

逆变部分/Inverter Part

符号 Symbol	参数 Parameter	条件 Condition	额定值 Ratings	单位 Unit
V _{CC}	电源电压 Supply voltage	应用于P-NU, NV, NW之间 Applied between P-NU, NV, NW	450	V
V _{CC (Surge)}	电源电压 (包含浪涌) Supply voltage(surge)	应用于P-NU, NV, NW之间 Applied between P-NU, NV, NW	500	V
V _{CES}	集电极-发射极间电压 Collector-emitter voltage		600	V
± I _c	集电极电流 Each IGBT collector current	T _c = 25°C (备注1) (Note1)	15	A
± I _{CP}	集电极电流 (峰值) Each IGBT collector current (peak)	T _c = 25°C, 脉冲宽度小于1ms T _c = 25°C, less than 1ms	30	A
P _c	集电极功耗 Collector power loss	T _c = 25°C, 单晶片 T _c = 25°C, single chip	74	W
T _j	结温 Junction temperature	(备注2) (Note 2)	-30~+150	°C

备注 1: 脉宽和周期受限于结温。

Note 1: Pulse width and period are limited due to junction temperature.

备注 2: IPM 内部功率晶片最大额定结温为 150°C(@表面温度 T_c≤125°C)。但是,为了确保 IPM 运行安全,结温应限于 T_{j(ave)}≤125°C (@表面温度 T_c≤100°C)。

Note 2: The maximum rated junction temperature of the IGBT is 150°C(@T_c≤125°C).To ensure the safe operation of IPM, the junction temperature should be limited to T_{j(ave)}≤125°C (@T_c≤100°C).

控制部分/Control(Protection)Part

符号 Symbol	参数 Parameter	条件 Condition	额定值 Ratings	单位 Unit
V _{DB}	上桥臂控制电源电压 P-side control supply voltage	应用于V _{UFB-U} , V _{VFB-V} , V _{WFB-W} 之间 Applied between V _{UFB-U} , V _{VFB-V} , V _{WFB-W}	20	V
V _D	控制电源电压 Control supply voltage	应用于V _{P1-V_{NC}} 和V _{N1-V_{NC}} 之间 Applied between V _{P1-V_{NC}} , V _{N1-V_{NC}}	20	V

V_{IN}	输入信号电压 Input voltage	应用于 $U_P, V_P, W_P, U_N, V_N, W_N - V_{NC}$ 之间 Applied between $U_P, V_P, W_P, U_N, V_N, W_N - V_{NC}$	$-0.5 \sim V_D + 0.5$	V
V_{FO}	故障输出电压 Fault output supply voltage	应用于 $F_0 - V_{NC}$ 之间 Applied between $F_0 - V_{NC}$	$-0.5 \sim V_D + 0.5$	V
I_{FO}	故障输出电流 Fault output current	F_0 端子灌入电流值 Sink current at F_0 terminal	10	mA
V_{SC}	电流检测端输入电压 Current sensing input voltage	应用于 $C_{IN} - V_{NC}$ 之间 Applied between $C_{IN} - V_{NC}$	$-0.5 \sim V_D + 0.5$	V

系统/Total System

符号 Symbol	参数 Parameter	条件 Condition	额定值 Ratings	单位 Unit
$V_{CC(Prot)}$	自保护电源电压限制（短路保护能力） Self-protection supply voltage limit (Short circuit protection capability)	$V_D = V_{DB} = 13.5 \sim 16.5V, T_j = 125^\circ C,$ 无重复, 时间小于2us $V_D = V_{DB} = 13.5-16.5V,$ inverter part $T_j = 125^\circ C,$ Non-repetitive, less than 2us	400	V
T_c	正常工作壳温 Module case operation temperature		$-30 \sim +100$	$^\circ C$
T_{STG}	贮存温度 Storage temperature		$-40 \sim +125$	$^\circ C$
V_{ISO}	绝缘耐压 Isolation voltage	60Hz, AC 1分钟, 在插脚和散热片之间 60HZ, AC1min, between connected all pins and heat-sink plate	1500	Vrms
$R_{th(j-c)Q}$	结点到外壳的热阻 Junction to case thermal resistance	单个IGBT芯片 Per IGBT part	1.67	$^\circ C/W$
$R_{th(j-c)F}$		单个FRD芯片 Per FRD part	2.34	$^\circ C/W$

壳温 TC 测试点/Tc Measurement Point



图 3: 壳温 TC 测试点

Fig 3: Tc measurement point

电气特性: (T_j= 25°C, 除非特殊说明)

Electrical Characteristics: (T_j= 25°C, unless otherwise noted)

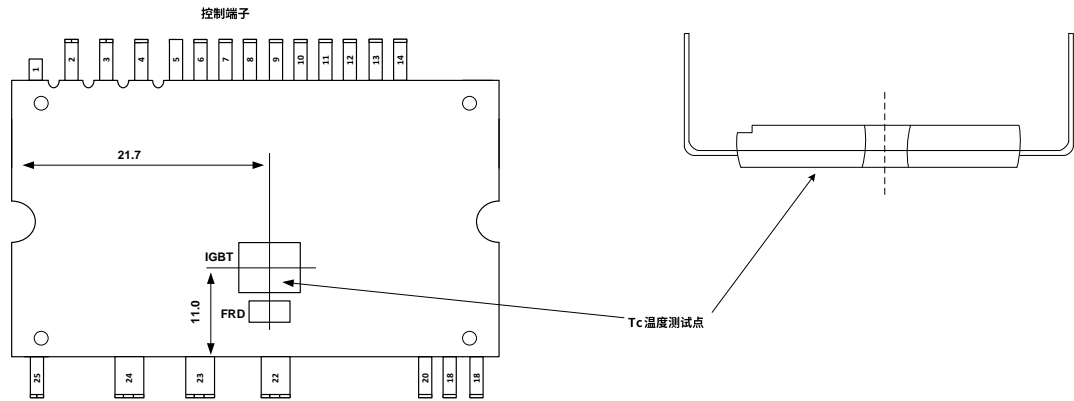
逆变部分/Inverter Part

符号 Symbol	项目 Parameter	条件 Condition	最小值 Min.	典型值 Typ.	最大值 Max.	单位 Unit
V _{CE(sat)}	集电极与发射极间饱和电压 Collector-emitter saturation voltage	V _D = V _{DB} = 15V V _{IN} = 5V, I _c = 15A, T _j = 25°C		1.7	2.1	V
		V _D = V _{DB} = 15V V _{IN} = 5V, I _c = 15A, T _j = 125°C		2.0		V
V _F	FWD 正向导通电压 FWD forward voltage	V _{IN} = 0V, I _c = 15A, T _j = 25°C		1.4	1.7	V
BV	BV电压 BV voltage	V _{CC} =V _{BS} =15V, I _c = 1mA	650			V
t _{ON}	开关时间 (备注 3) switching time (Note 3)	V _{CC} = 400V, V _D = V _{DB} = 15V, I _c =15A, V _{IN} = 0V~5V, inductive loading		730		ns
t _{C(ON)}				180		ns
t _{OFF}				990		ns
t _{C(OFF)}				140		ns
t _{rr}				170		ns
I _{CES}	集电极到发射极漏电流 Collector-emitter cut-off current	V _{CE} = V _{CES} , T _j = 25°C			1	mA
		V _{CE} = V _{CES} , T _j = 125°C			10	mA

备注 3: t_{ON} 和 t_{OFF} 包括驱动 I_c 内部传输延迟时间。 $t_{C(ON)}$ 和 $t_{C(OFF)}$ 是 IGBT 自身被内部给定门极驱动条件下的开关时间。具体请参考开关时间定义。

Note 3: t_{ON} and t_{OFF} include the internal transmission delay time of the driver IC. $t_{C(ON)}$ and $t_{C(OFF)}$ are the switching times of the IGBT itself under the internal given gate driving conditions. Please refer to switching time definition for details.

开关时间定义/Switching Time Definition



图 4: 开关时间定义
Fig 4: Switching Time Definition

控制部分 (Tj= 25°C, 除非特殊说明)

Control (Protection) Part (Tj= 25°C, unless otherwise noted)

符号 Symbol	项目 Parameter	条件 Condition	最小值 Min.	典型值 Typ.	最大值 Max.	单位 Unit
I_D	V_D 静态电流 Quiescent V_D current	$V_D = 15V, V_{IN} = 0V, V_{P1}-V_{NC}$			1.6	mA
		$V_D = 15V, V_{IN} = 5V, V_{P1}-V_{NC}$				
I_{DB}	V_{DB} 静态电流 Quiescent V_{DB} current	$V_{DB} = 15V, V_{IN} = 0V, V_{UFB}-U, V_{VFB}-V, V_{WFB}-W$			0.1	mA
		$V_{DB} = 15V, V_{IN}=5V, V_{UFB}-U, V_{VFB}-V, V_{WFB}-W$				
I_{IN}	输入电流 Input current	$V_{IN} = 5V$		1	1.5	mA
$V_{th(on)}$	开通阈值电压 ON threshold voltage	应用 $U_P/V_P/W_P/U_N/V_N/W_N-V_{NC}$ 之间 Applied between $U_P/V_P/W_P/U_N/V_N/W_N-V_{NC}$		2.5	3	V
$V_{th(off)}$	关断阈值电压 OFF threshold voltage		0.8	1.3		V
UV_{Dt}	电源欠压保护控制 Control supply under-voltage protection	低侧触发电平 Trip level(L)	10.5	11.5	12.5	V
UV_{Dr}		低侧复位电平 Reset level(L)	11.0	12.3	13.0	V
UV_{DBt}		高侧触发电平 Trip level(H)	9.5	10.5	11.5	V

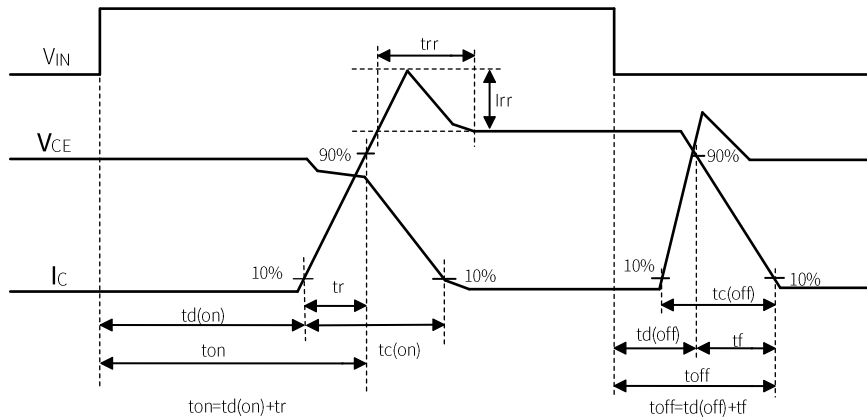
UV _{DBr}		高侧复位电平 Reset level(H)	10.5	11.5	12.5	V	
V _{FOH}	故障输出电压 Fault output voltage	V _{SC} = 0V, F _O 通过10K电阻上拉至5V V _{SC} = 0V, F _O pulled up to 5V by 10KΩ	4.7			V	
V _{FOL}	故障输出电压 Fault output voltage	V _{SC} = 1V, F _O 通过10K电阻上拉至5V V _{SC} = 1V, F _O pulled up to 5V by 10KΩ			0.3	V	
V _{SC (ref)}	过流保护触发阈值 Short circuit trip level	V _D = 15V	0.455	0.480	0.505	V	
V _{OT}	温度输出 Temperature Output	T _C = 25°C		1.1		V	
		T _C = 90°C	2.54	2.77	2.91	V	
T _{FILIN}	输入信号滤波时间 Input filter time	V _{IN} = 0 V & 5 V		350		ns	
T _{FO}	故障输出脉冲宽度 Fault output pulse width		60			us	
T _{CIN}	CIN 输入信号滤波时间 CIN signal filter time			700		ns	
OT _t	过温保护阈值 Over temperature protection	LVIC 温度 LVIC temperature	触发温度 Trip level	115	125	135	°C
OT _{rh}			复位温度 Hysteresis of trip-reset	105	115	125	°C
V _F	正向电压	I _F = 10mA, T _C = 25°C		2.6		V	
R _{BSD}	自举电阻 Built-in limiting resistance	(包括自举二极管) (Included in bootstrap Diode)	150	180	210	ohm	



图 5：自举二极管特性曲线

Fig5: bootstrap diode characteristic curve

V_{OT} 输出曲线/V_{OT} Output Curve

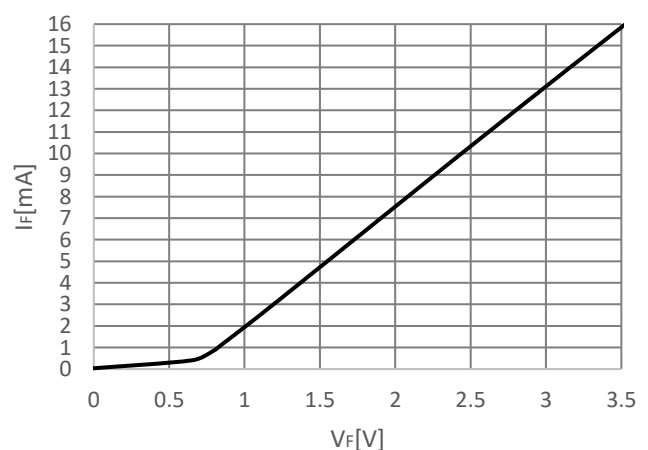
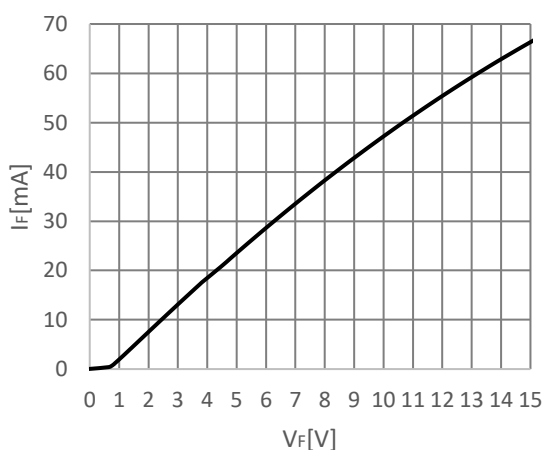

图 6: LVIC 温度-V_{OT} 输出特性

Fig6: LVIC temperature-V_{OT} output characteristics

推荐工作条件/Recommended Operation Conditions

符号 Symbol	项目 Parameter	条件 Parameter	最小值 Min.	典型值 Min.	最大值 Max	单位 Unit
V _{CC}	电源电压 Supply voltage	应用于P-NU/NV/NW之间 Applied between P-NU/NV/NW	0	300	400	V
V _D	控制电源电压 Control supply voltage	应用于V _{P1} -V _{NC} 之间 Applied between V _{P1} -V _{NC}	13.5	15	16.5	V
V _{DB}	上臂控制电源电压 Top side supply voltage	应用于V _{UFB-U} /V _{VFB-V} /V _{WFB-W} 之间 Applied between V _{UFB-U} /V _{VFB-V} -V _{WFB-W}	13.5	15	18.5	V
T _{dead}	死区时间 Dead time	各桥臂输入对应, T _C ≤ 100°C For each input signal, T _C ≤ 100°C	1			us

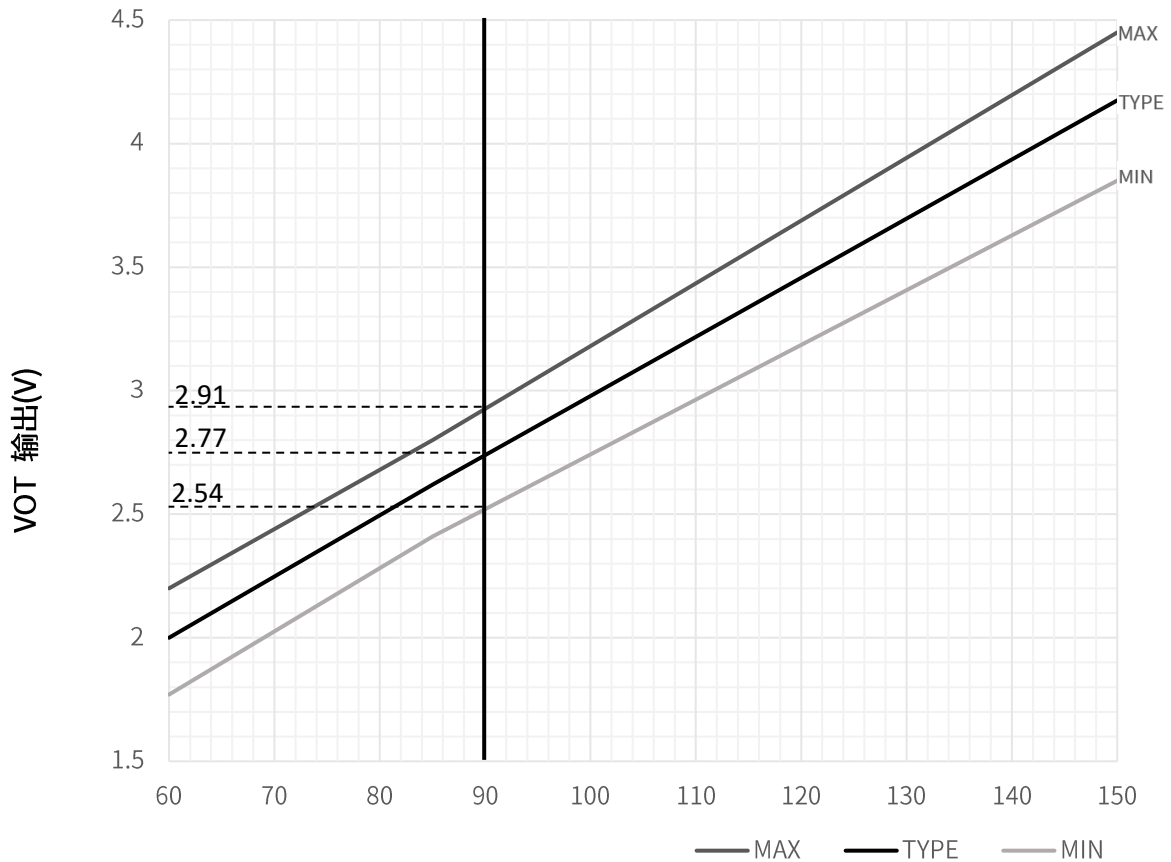
$\Delta V_D/\Delta V_{DB}$	控制电源纹波 Control supply variation		-1		1	V/us
f_{PWM}	PWM 频率 PWM input frequency	$-20^{\circ}\text{C} \leq T_c \leq +100^{\circ}\text{C}$ $-20^{\circ}\text{C} \leq T_j \leq +125^{\circ}\text{C}$			20	kHz
PWM(ON/OFF)	最小输入信号脉冲宽度 Minimum input pulse width	ON	0.7			us
		OFF	0.7			us
V_{NC}	V_{NC} variation	Between V_{NC-NU} , NV , NW (including surge)	-5		5	V
T_j	结温 Junction temperature		-20		125	$^{\circ}\text{C}$

机械特性/Mechanical Characteristics And Ratings

参数 Parameter	条件 Conditions	最小值 Min.	典型值 Typ.	最大值 Max.	单位 Unit
安装扭矩 Mounting torque	螺丝钉尺寸: M3 Mounting screw: M3	0.59	0.69	0.78	N·m
设计平面度 Heat-sink flatness	(备注4) (Note4)	-50		+100	um
重量 Weight			9		g

备注 4: 散热部分平整度的测量位置如下

Note4: Measurement positions of heat radiation part flatness are as below

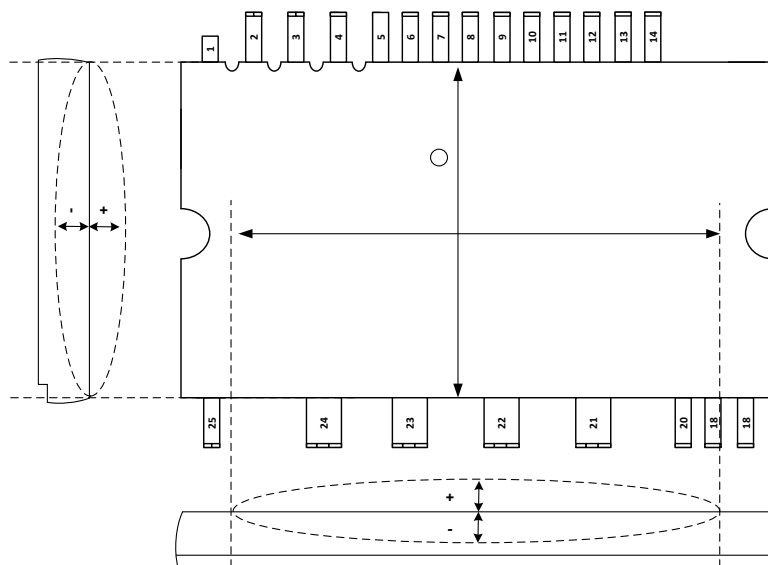

应用指南 Application Guide

欠压保护/Under-Voltage Protection



图 7: 欠压保护时序图 (低侧)

Fig7: Under-voltage protection timing charts (Low-side)

a1: 电源电压上升: 电压上升到欠压恢复点, 在下一个欠压信号被执行前该电路将启动运行。

a1: Power supply voltage rise: when the voltage exceeds the under voltage reset level, the circuit works in normal before the next under voltage signal is executed.

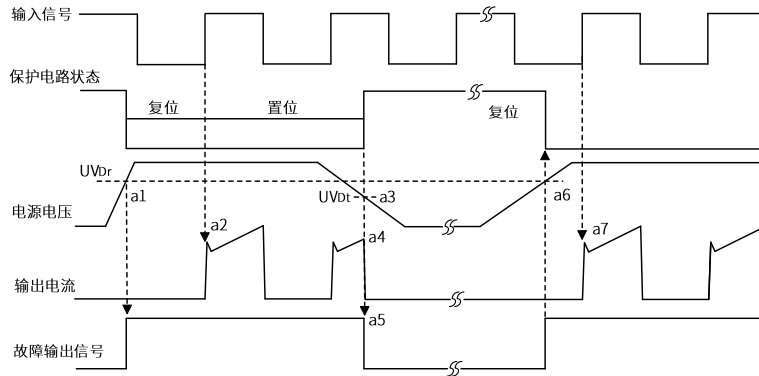
a2: 正常运行: IGBT 开启并加载电流。

a2: Normal operation: IGBT ON and outputs current.

a3: 欠压检测点(UV_{dt})。

a3: VD level drops to under voltage trip level (UV_{dt}).

a4: 不管输入是什么信号, IGBT 都是关闭状态。

a4: All N-side IGBTs turn OFF regardless of control input condition.

a5: 故障输出开启。

a5: Fo outputs operation starts.

a6: 欠压恢复(UV_{dr})。

a6: VD level reaches UV_{dr} .

a7: 正常运行: IGBT 导通并加载负载电流。

a7: Normal operation: IGBT ON and carrying current.



图 8: 欠压保护时序图 (高侧)

Fig 8: Under-voltage protection timing charts (High-side)

- b1: 电源电压上升: 当该电压上升到欠压恢复点, 在下一个欠压信号被执行前该电路将启动运行。
 b1.: Control supply voltage V_{DB} rises: after the voltage reaches under voltage reset level UV_{DBr} , IGBT turns on by the next ON signal(L→H).
- b2: 正常运行: IGBT 导通并加载。
 b2: Normal operation: IGBT ON and outputs current.
- b3: 欠压检测 (UV_{DBt})。
 b3: V_{DB} level drops to under voltage trip level (UV_{DBt}).
- b4: 不管输入是什么信号, IGBT 都是关闭状态。
 b4: IGBT of the correspond phase only turns OFF regardless of the input signal, but there is no FO signal output.
- b5: 欠压恢复(UV_{DBr})。
 b5: V_{DB} level reaches UV_{DBr} .
- b6: 正常运行: IGBT 导通并加载负载电流。
 b6: Normal operation: IGBT ON and outputs current.

短路保护/Short Circuit Protection

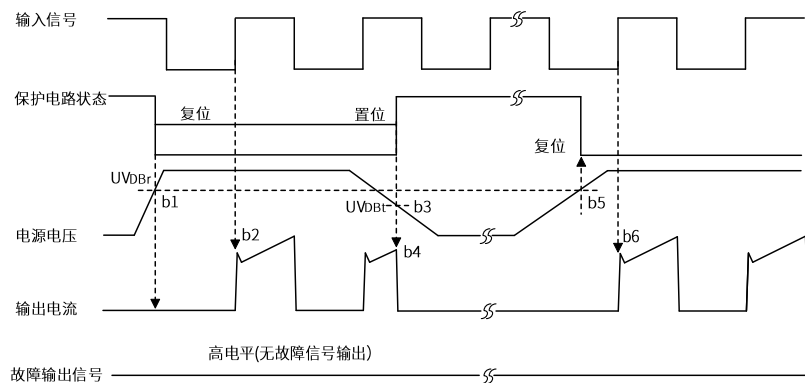

图 9: 短路电流保护时序图

Fig9: Short circuit protection timing charts

- c1: 正常运行: IGBT 导通载流。
 c1: Normal operation: IGBT ON and carrying current.
- c2: 短路电流检测(Cin 短路触发)。
 c2: Short circuit current detection (SC trigger).
- c3: 所有 N 侧 IGBT 栅极被强制关断。
 c3: All N-side IGBT's gates are hard interrupted.
- c4: 所有 N 侧 IGBT 被关断。
 c4: all N-side IGBTs turn OFF.
- c5: 故障输出脚输出一个固定的脉宽信号 ($t_{Fo} \geq 60\mu s$)。

- c5: The fault output pin outputs a fixed pulse width signal($t_{Fo} \geq 60\mu s$).
- c6: 输入“L” :IGBT 关闭。
- c6: Input “L” :IGBT OFF.
- c7: 输入“H” :IGBT 开通,但在故障输出期间,IGBT 仍然是关断状态。
- c7: Input= “H” :IGBT ON,in case of the F_o signal works, the IGBT still OFF.
- c8: 正常工作: IGBT 导通, 输出电流。
- c8: Normal operation: IGBT conduction, output current.

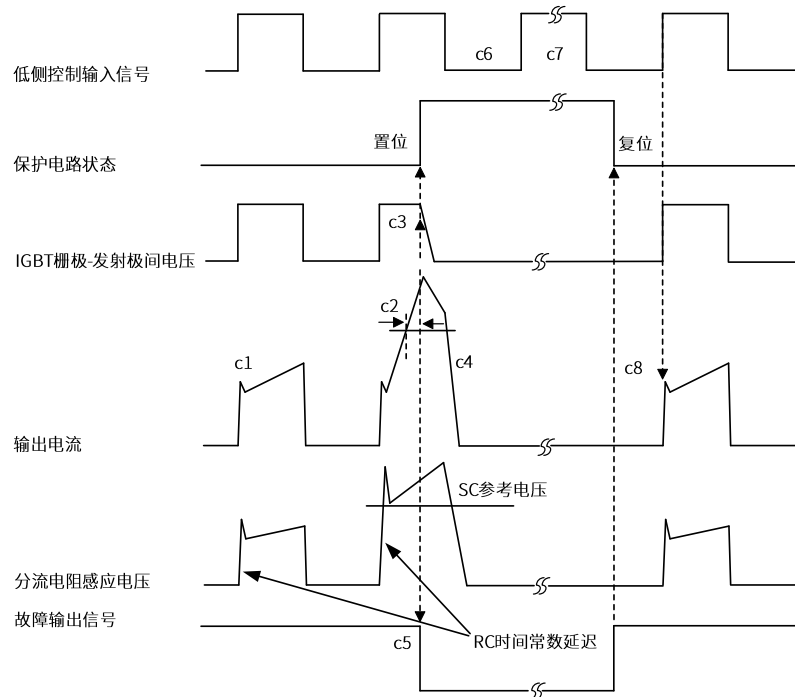
过温保护(N 侧)/Over Temperature Protection(N-side, Detecting LVIC temperature)



图 10: 过温保护时序图

Fig10: Over Temperature protection timing charts

- d1: 正常工作: IGBT 开通, 输出电流。
- d1: Normal operation: IGBT ON and outputs current.
- d2: LVIC 温度超过过温保护触发点(OT_t)。
- d2: LVIC temperature exceeds over temperature trip level (OT_t).
- d3: 无论输入什么信号, 所有 N 侧 IGBT 关断。
- d3: All N-side IGBTs turn OFF in spite of control input condition.
- d4: F_o 输出最小 60us 故障信号, 在过温期间, F_o 会持续输出故障信号。
- d4: F_o outputs for $t_{Fo} = \text{minimum } 60\mu s$, but output is extended during LVIC temperature keeps over OT_t .
- d5: LVIC 温度降到过温保护复位水平。
- d5: LVIC temperature drops to over temperature reset level.
- d6: 正常工作: 当下一个开通信号到来时, IGBT 正常开通。
- d6: Normal operation: IGBT turns on by next ON signal (L→H).

输入/输出接口电路/Input/Output Interface Circuit

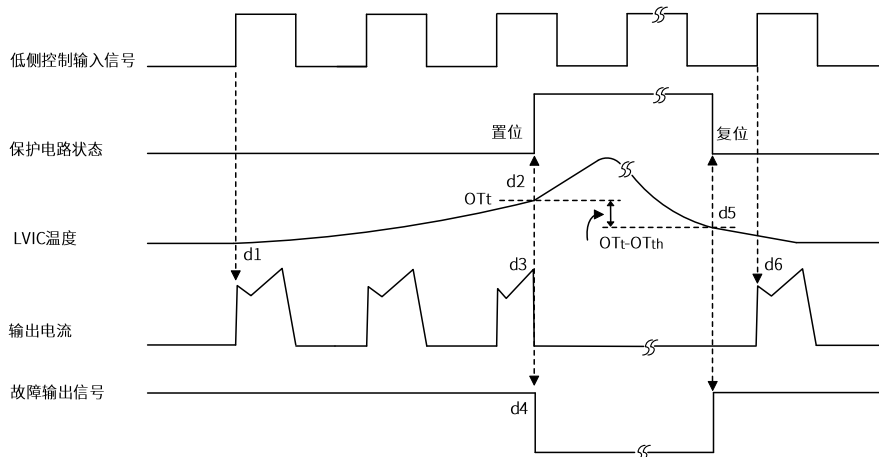

图 11: MCU 输入/输出连接电路 (推荐)

Fig11: MCU I/O Interface Circuit (Recommended)

备注 5: 控制输入端的 RC 滤波容量的选择取决于应用系统的 PWM 控制方式和 PCB 的引线阻抗。

Note 5: The RC coupling (parts shown in the dotted line) at each input depends on user's PWM control strategy and the wiring impedance of the printed circuit board.

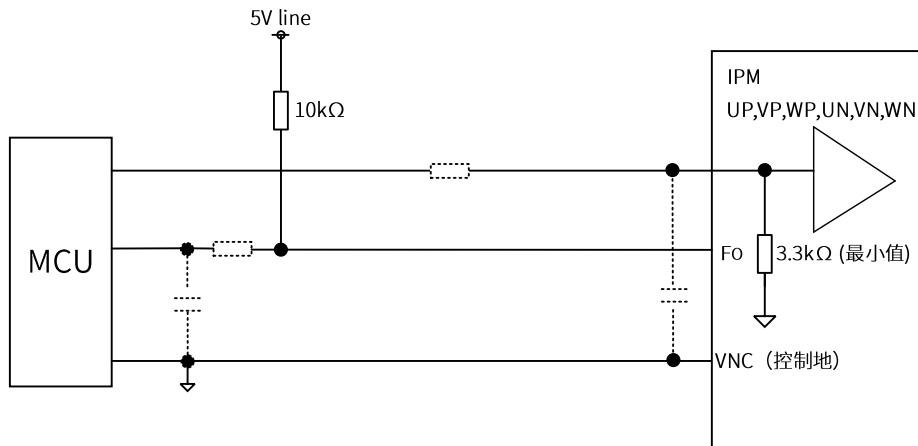
备注 6: 控制输入在模块内部接有 3.3KΩ 的下拉电阻, 因此, 当外接滤波电阻时, 请注意在输入端子上的控制信号压降 (它应满足控制电压阈值的要求)。

Note 6: The DI/IPM signal input section integrates a 3.3kΩ(min) pull-down resistor. Therefore, when using an external filtering.

分流电阻接线/Wiring Around The Shunt Resistor



图 12: 旁路电阻接线注意事项

Fig12: Recommended Wiring Around The Shunt Resistor

典型应用电路图/Typical Application Circuit

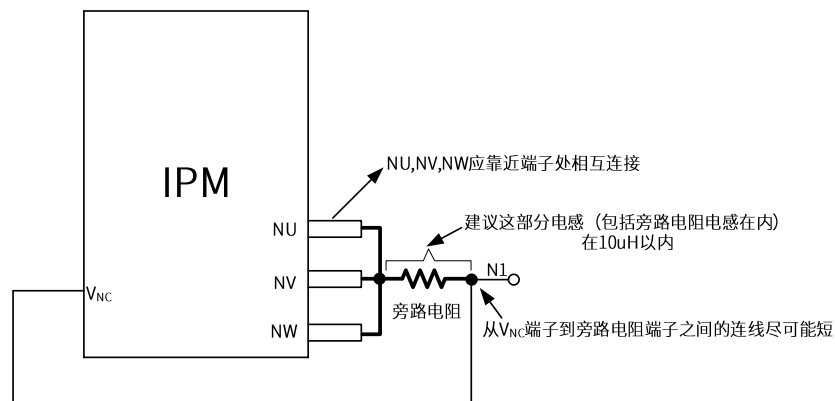

图 13: 典型应用电路

Fig13: Typical Application Circuit

备注/Note

- 1.建议信号地和功率地在 N1 处单点连接。
1.It is recommended to connect control GND and power GND at only a point N1 (near the terminal of shunt resistor).
- 2.为防止浪涌损坏, 建议在每一路电源引脚与地之间接 18V/1W 的稳压管。
2.It is recommended to insert a Zener diode D1(18V/1W) between each pair of control supply terminals to prevent surge destruction.
- 3.为防止浪涌破坏, 建议在 P/N1 端子之间增加一个缓冲电容 C3。电容容值一般在 0.1 ~ 0.22 μ F, 且电容的走线尽量短。
3.To prevent surge destruction, the wiring between the smoothing capacitor and the P, N1 terminals should be as short as possible. Generally a 0.1-0.22 μ F snubber capacitor C3 between the P-N1 terminals is recommended.
- 4.R1, C4 型 RC 滤波器为防止保护电路故障, 建议选用精确、温度补偿型。设置时间常数 R1C4, 使 SC 电流在 2 μ s 内关断。(一般值为 1.5 μ s~2 μ s)SC 关断时间随走线方式不同而不同, 因此有必要对实际系统进行充分的评估。
4.R1, C4 of RC filter for preventing protection circuit malfunction is recommended to select tight tolerance, temp-compensated type. The time constant R1C4 should be set so that SC current is shut down within 2 μ s. (1.5 μ s~2 μ s is general value.) SC interrupting time might vary with the wiring pattern, so the enough evaluation on the real system is necessary.
- 5.为防止干扰, A,B,C 处的线应尽量短。
5.To prevent malfunction, the wiring of A, B, C should be as short as possible.
- 6.CIN 引脚的滤波电路应接在 D 点附近, NU, NV, NW 端子应靠近旁路电阻连接。
6.The point D at which the wiring to CIN filter is divided should be near the terminal of shunt resistor. NU, NV, NW terminals should be connected at near NU, NV, NW terminals.
- 7.所有电容应尽可能靠近端子安装。(C1:温度、频率特性良好的电解型;C2:0.22 μ -2 μ F, 温度、频率、直流偏置特性良好的陶瓷型。)
7.All capacitors should be mounted as close to the terminals as possible. (C1: good temperature, frequency characteristic electrolytic type and C2:0.22 μ -2 μ F, good temperature, frequency and DC bias characteristic ceramic type are recommended.)
- 8.模块输入内部有一个最小的 3.3k Ω 下拉电阻。为了防止故障, 每个输入的接线应尽可能短。使用 RC 滤波电路时, 应保证输入信号电平满足通断阈值电压。
8.There is a minimum 3.3k Ω pull-down resistor in the input circuit of IPM. To prevent malfunction, the wiring of each input should be as short as possible. When using RC coupling circuit, make sure the input signal level meet the turn-on and turn-off threshold voltage.
- 9.Fo 输出为开漏式。它应该通过一个电阻上拉到 MCU 或控制电源(例如 5V,15V), 使 IFo 达到 1mA。(IFO 由控制电源电压除以上拉电阻的公式粗略估计。在拉到 5V 的情况下, 建议使用 5k Ω)。
9.Fo output is open drain type. It should be pulled up to MCU or control power supply (e.g. 5V,15V) by a resistor that makes IFo up to 1mA. (IFO is estimated roughly by the formula of control power supply voltage divided by pull-up resistance. In the case of pulled up to 5V, 10k Ω is recommended.)

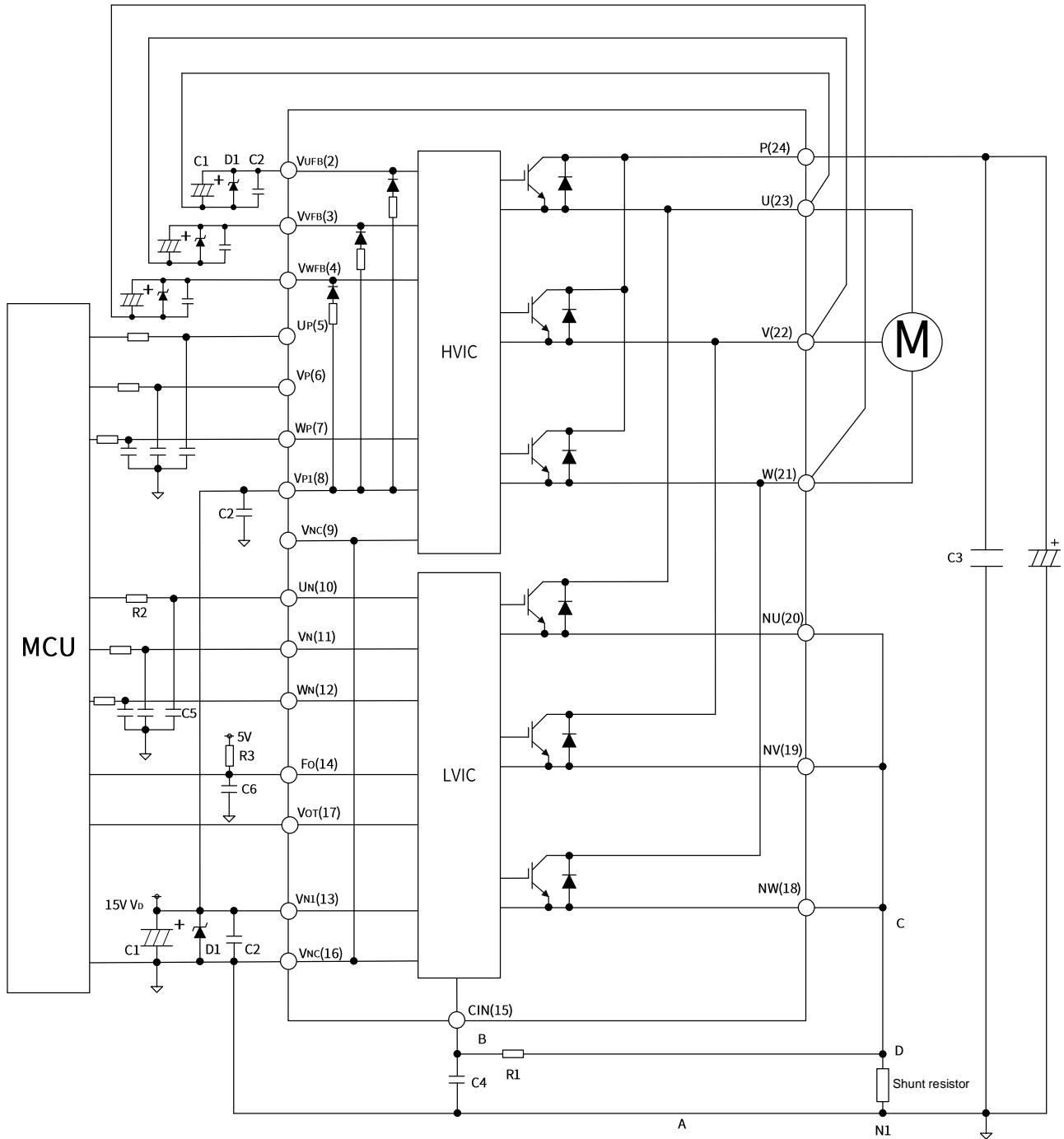
封装外形图/ Package Outline Drawing

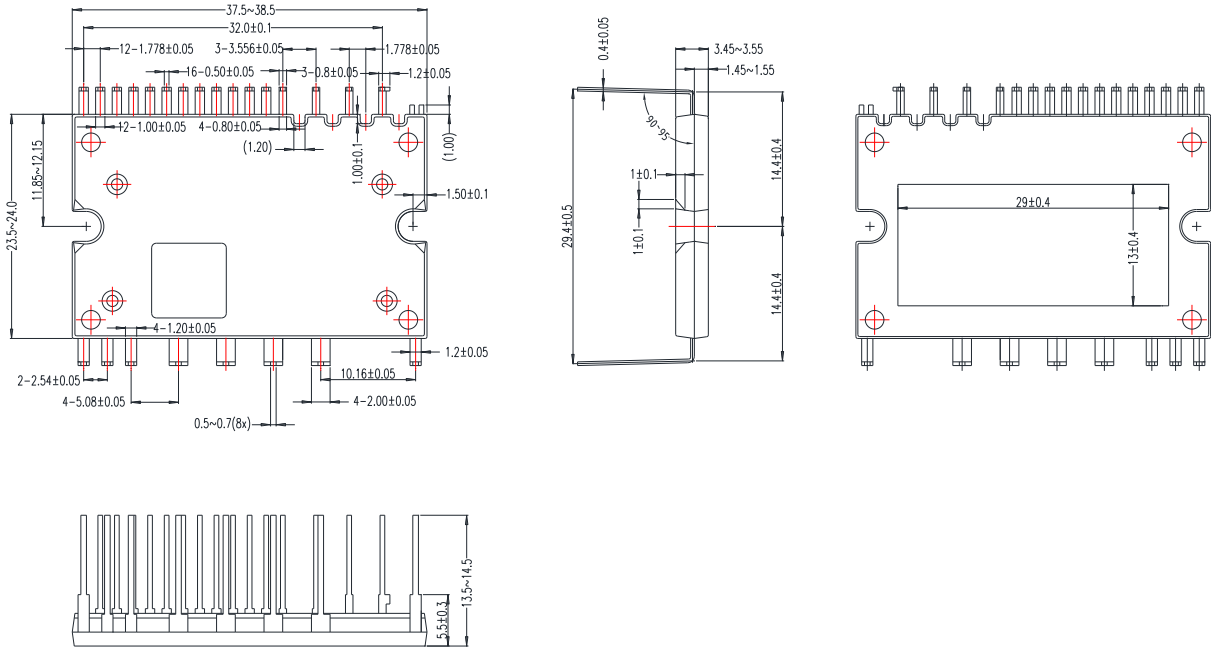

修订历史 REVISE HISTORY

日期 Date	版本 Version	修订明细 Update detail
2024.09.06	1.0	第一版

重要通知

本文提到的信息，特别是本文所述的案例、提示或任何典型值和/或关于产品应用的一切信息，在任何情况下均不应被视为明示或暗示的保证或授权，包括但不限于基于特定用途的准确性、完整性、适销性、适用性，或不侵犯任何第三方知识产权的担保。

仅使用者本人，应对使用广东巨风半导体有限公司产品或应用，以及安全承担责任。使用者应当遵守与广东巨风半导体有限公司产品或应用程序有关的所有法律、法规和要求，但与产品应用有关的信息和技术支持可能仍由广东巨风半导体有限公司提供。

本文档包含的信息仅供经培训的开发人员，为了对广东巨风半导体有限公司进行产品设计而使用。广东巨风半导体有限公司保留对所提供的产品和服务进行更正、修改、增强、改进或其他变更的权力。广东巨风半导体有限公司仅授权您将这些信息用于开发整合广东巨风半导体有限公司产品的相关程序。未经授权，禁止将这些信息用于其他用途，或复制、展示。对上述信息的使用，所产生的任何索赔、损害、费用、损失或责任，广东巨风半导体有限公司不承担任何责任。

警告

由于技术需求，产品可能含有危险物质。

除非广东巨风半导体有限公司在其授权代表签署的书面文件中另行明确，否则广东巨风半导体有限公司的产品不得用于故障产品或可能导致人身损害的情形下。

更多产品、应用和技术信息，请联系广东巨风半导体有限公司(www.trexttech.cn)。

广东巨风半导体有限公司

IMPORTANT NOTICE

The information given in this document, especially examples, hints or any typical values stated herein and/or any information regarding the application of the product, shall in no event be regarded as any warranty of authorization of, express of implied, including but not limited to accuracy, completeness, merchantability, fitness for a particular purpose or infringement of any third party's intellectual property rights.

The user is solely responsible for the use of TREX's products and applications, and for the safety thereof. The user shall comply with all laws, regulations and requirements related to TREX's products and applications, although information or support related to any application may still be provided by TREX.

The information is intended only for skilled developers designing with TREX's products. TREX reserves the rights to make corrections, modifications, enhancements, improvements or other changes to the products and services provided. TREX authorizes you to use this information exclusively for the development of relevant applications designed to integrate TREX's products. Using this information for any other purpose, or any unauthorized reproduction or display of these resources is strictly prohibited. TREX Shall not be liable for any claims, damages, costs, losses or liabilities arising out of the use of these resources.

WARNINGS

Due to technical requirements products may contain dangerous substances.

Except as otherwise explicitly approved by TREX Technologies Corporation in a written document signed by authorized representatives of TREX Technologies Corporation, TREX's products may not be used in any applications where a failure of the product or any consequences of the use thereof can reasonably be expected to result in personal injury.

For further information on applications, products and technologies, please contact TREX(www.trexttech.cn).

TREX Technologies Corporation